

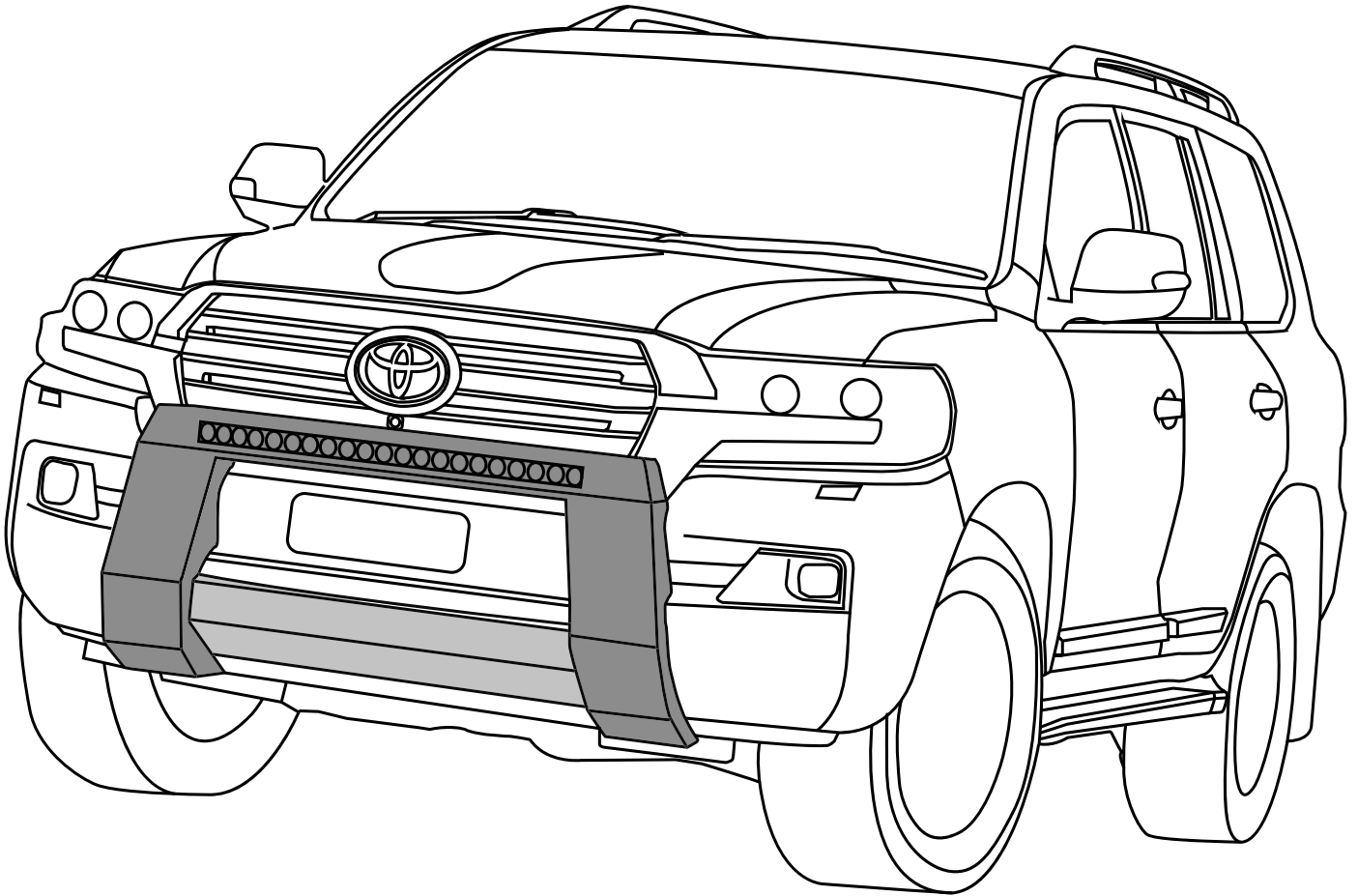

# FITTING INSTRUCTIONS



## NUDGE BAR

TO SUIT  
TOYOTA LANDCRUISER  
200 SERIES  
2015 - ON

**WARNING!**

When installed in accordance with these instructions, the VFPS (Vehicle Frontal Protection System) will not effect the operation of the vehicle's SRS airbag.

**NOTE**

- Do not attach the VFPS to the vehicle using anchorages not intended for this purpose (e.g. engine mounting bolts)
- Do not use this product for any vehicle make or model, other than those specified by Ultimate9®
- Do not remove the identification plaque or label from the VFPS.
- Do not modify the structure of the VFPS in any way
- The installation of this product may require the use of additional materials, specialised tools, and/or techniques. Please read and understand the instructions thoroughly before commencing any fitment.

**THE FOLLOWING SYMBOLS ARE USED IN THESE FITTING INSTRUCTIONS**

Warning - Read the included note carefully as damage may result



Danger - Must read before continuing as injury may result



Eye Protection - The following step requires the use of protective eye wear



Hearing Protection - The following step requires the use of protective ear muffs or plugs



Tip - Follow to make fitting easier or to save time



Special tools required

**GET THE LATEST INSTRUCTION UPDATE**

Go to [www.ultimate9.co](http://www.ultimate9.co) for the latest downloadable PDF version of this instruction booklet.



**FITTING INSTRUCTIONS**  
NUDGE BAR TO SUIT  
**TOYOTA LANDCRUISER 200 SERIES**  
**2015 - ON**

**GENERAL TOOLS REQUIRED FOR FITMENT**

Metric Socket Set	Metric Ring & Open End Spanners
Phillips And Flat Blade Screw Drivers	Sharp Knife
Drill Bit Set - Metric	Tin Snips Or Hacksaw
File Or Sandpaper	

**SPECIAL TOOLS REQUIRED FOR FITMENT**

Torque Wrench 3/8" Drive	Torque Wrench 1/2" Drive
#30 Torx Bit (For Inner Guard Removal)	Plastic Trim/Clip Removal Tools
Step Drill - 6-20mm	UTILUX #124 Crimp Tool

**GENERAL TORQUE SPECIFICATIONS**

**Note: In absence of notation or manufacturers spec use the below as a guide**

SIZE	TORQUE (Nm)	TORQUE (lb/ft)
M6	9	7
M8	22	16
M10	44	32
M12	77	57

**GENERAL CARE & MAINTENANCE**

Ultimate9 Nudge Bars are finished in durable powder coatings that are best maintained by regular washing with automotive grade detergents. The surface should be protected by polishing with automotive grade waxes at no more 6 month intervals to retain its original finish.

All fasteners should be checked for integrity at normal vehicle service intervals to ensure continued compliance with SRS airbag operation.



**FITTING INSTRUCTIONS**  
 NUDGE BAR TO SUIT  
**TOYOTA LANDCRUISER 200 SERIES**  
**2015 - ON**

APPLICATION	QTY	PART N/O.	DESCRIPTION
Chassis mounts to chassis	1	700-0002R	WELDED CHASSIS MOUNT - LANDCRUISER 200 SERIES RH
	1	700-0002L	WELDED CHASSIS MOUNT - LANDCRUISER 200 SERIES LH
Camera mount to nudge bar	1	300-0007	BRACKET - CAMERA MOUNT
	2	602-0004	NUT CAGED - M6 0.7-1.6
	2	603-0003	WASHER FLAT SS - M6 X 12.5 x 1.2
	2	601-0004	BUTTON HEAD CAP SCREW - M6 X 16
Light bar to nudge bar	2	300-0009	BRACKET - LIGHT MOUNT
	1	ULTLED30C	LED LIGHT BAR 30INCH COMBO
Nudge bar to chassis mounts	1	700-0001	WELDED ASSEMBLY NUDGE BAR - LC 200 SERIES 2015 ON
	4	601-0001	BOLT HEX HEAD-M10 X 30 GRADE 8.8
	8	603-0002	WASHER FLAT-M10 X 21 X 1.6
	4	602-0002	NUT NYLOC-M10
Nudge bar supports to radiator support	1	300-0008R	BRACKET - BAR SUPPORT RH
	1	300-0008L	BRACKET - BAR SUPPORT LH
	4	602-0003	NUT CAGED - M6 2.6 -3.5
	2	604-0001	BOLT SEMS - M6 X 20 GRADE 8.8
Centre pan to nudge bar	1	300-0004	PANEL-CENTER
	4	603-0003	WASHER FLAT SS-M6 X 12.5 X 1.2
	4	601-0004	BUTTON HEAD CAP SCREW-M6 X 16
	4	602-0003	NUT CAGED-M6 2.6 - 3.5
Wiring of light bar	1	ULTLEDPH01	HIGH BEAM PICK UP HARNESS
	1	ULTLEDHT	AUXILIARY LIGHT HARNESS (TWIN OUTPUT)
	1	ULTLEDSW001	DASH MOUNT SWITCH - 200 SERIES
	20	606-0001	CABLE TIE - 280MM X 4.8MM
	1	300-0029	BRACKET-RELAY MOUNT SINGLE
	1	601-0008	BOLT-M5 X 12
	1	603-0007	WASHER FLAT-M5
	1	602-0008	NUT NYLOC-M5

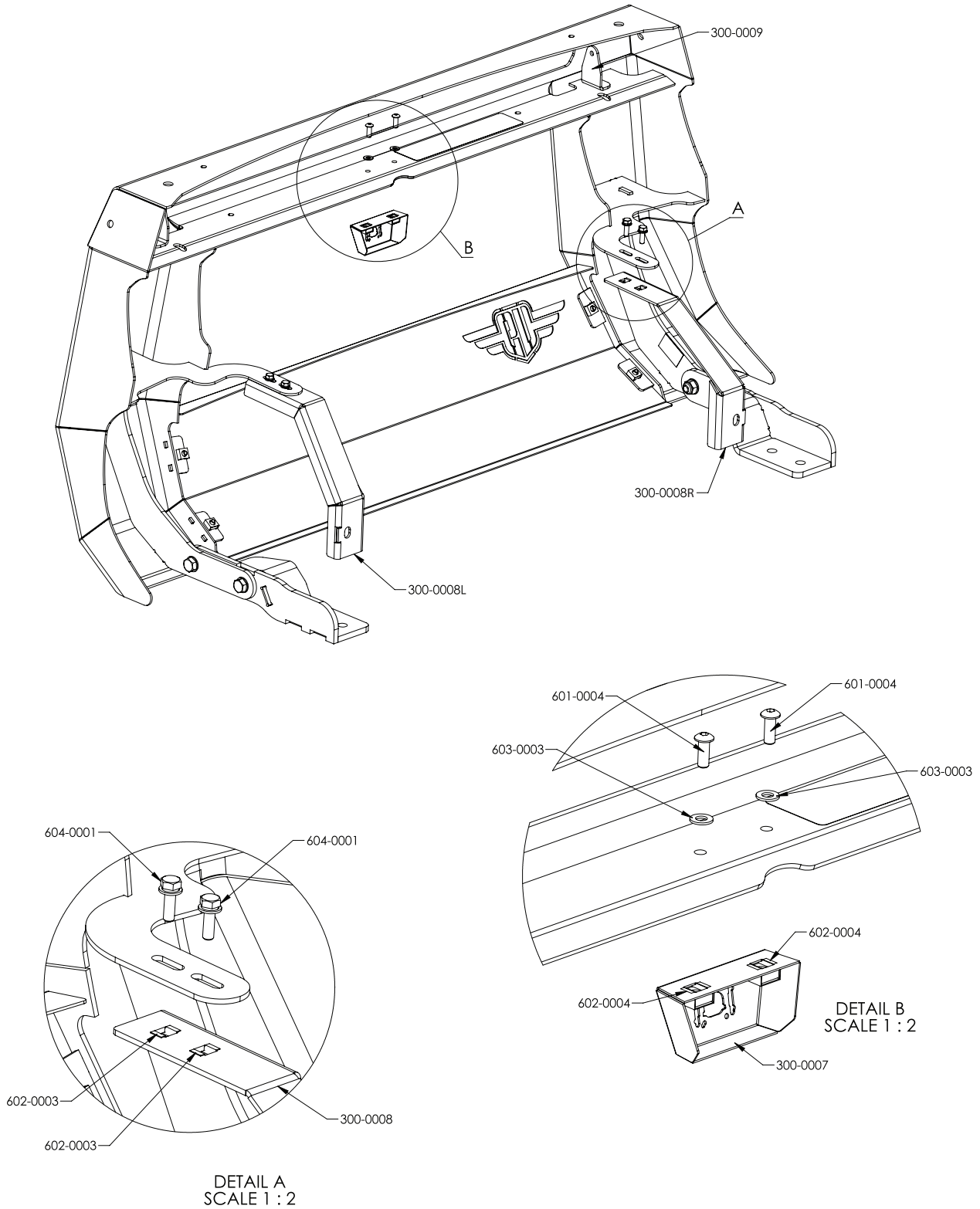

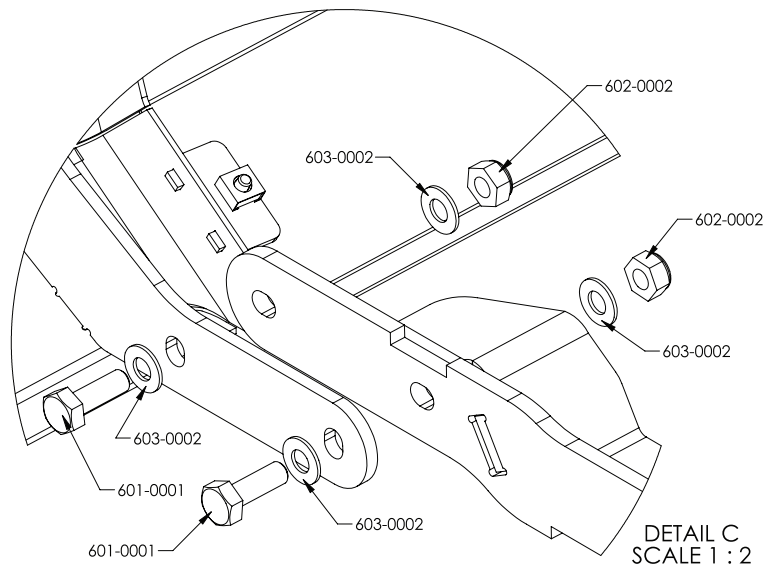
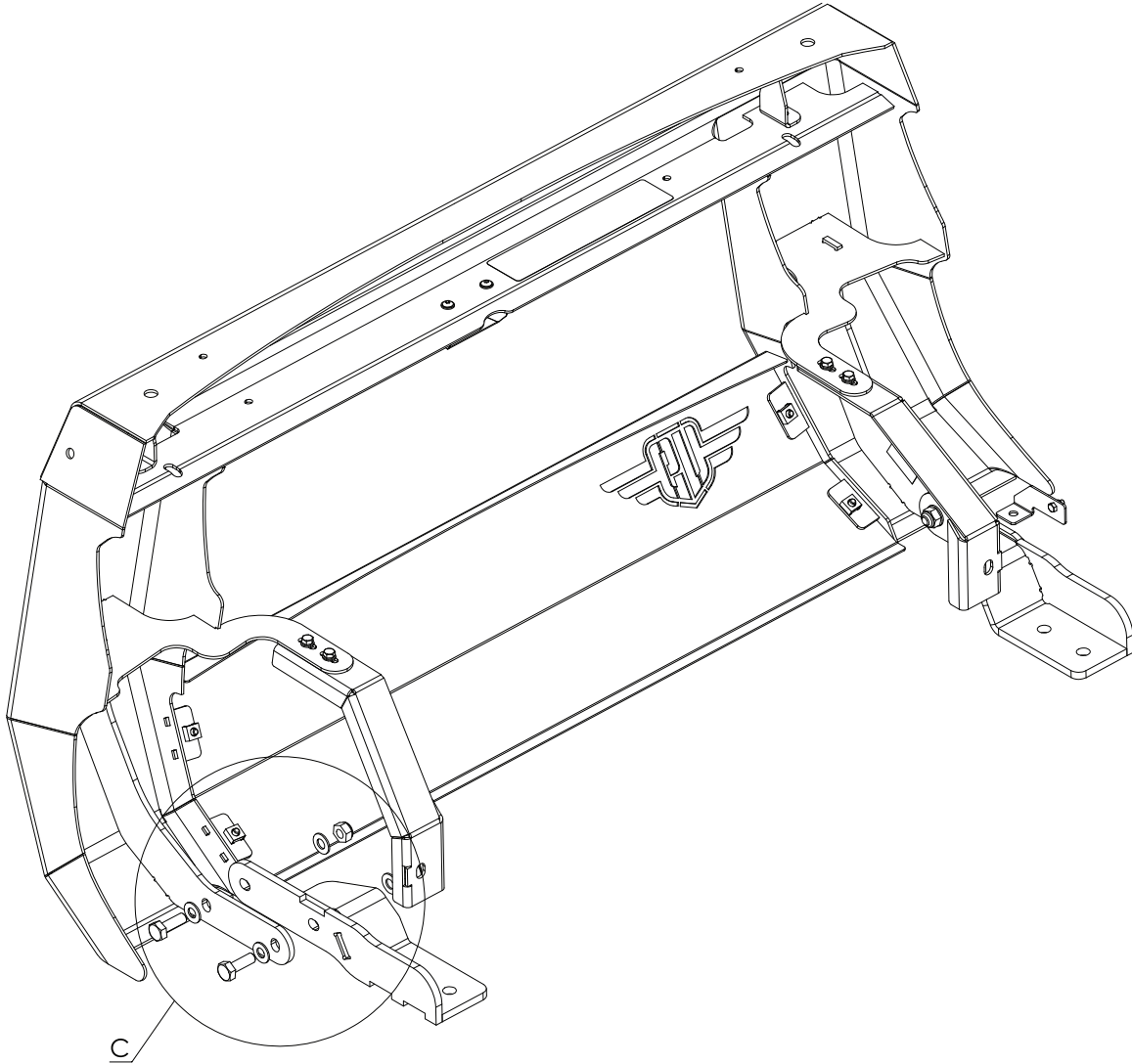

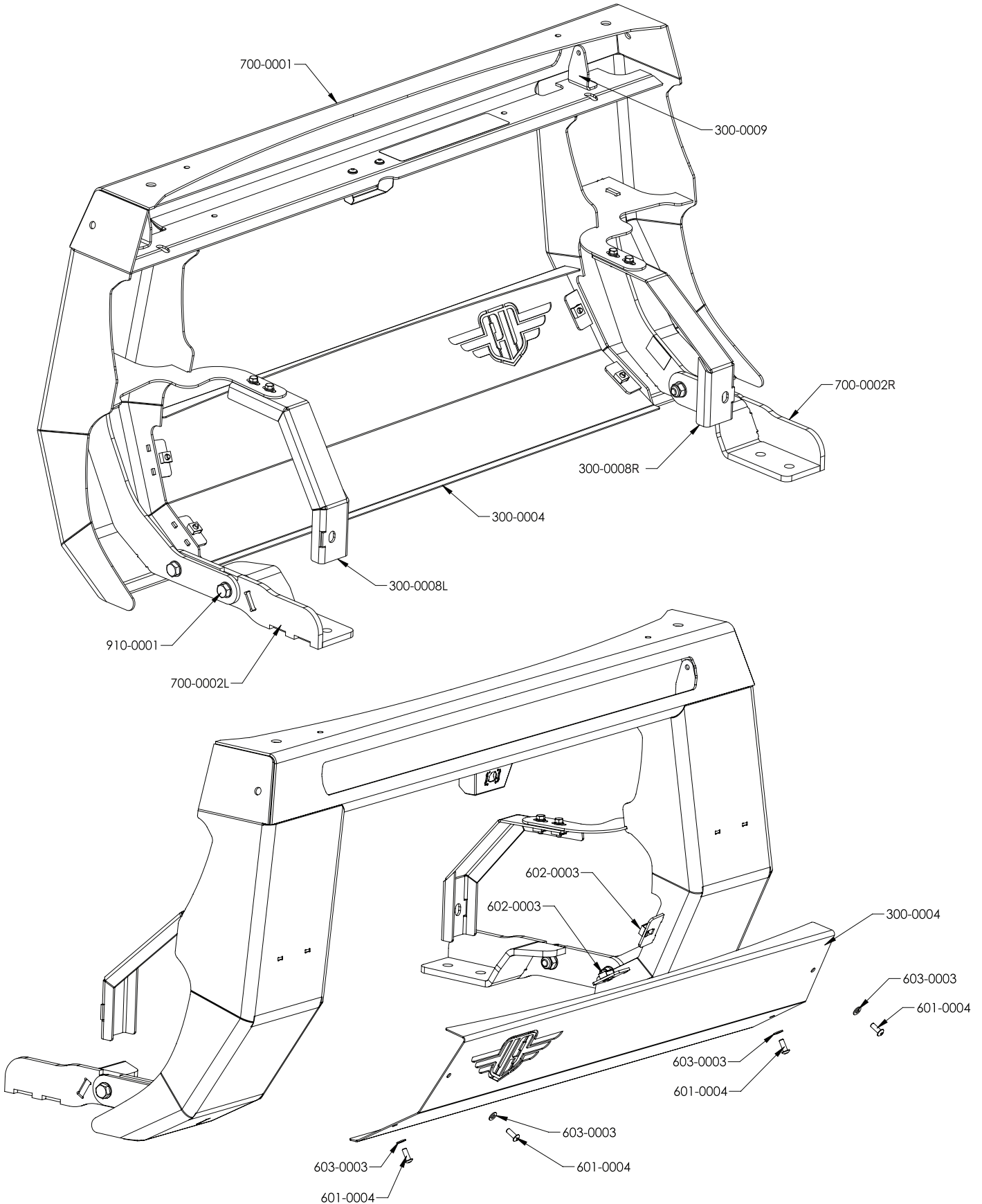

1

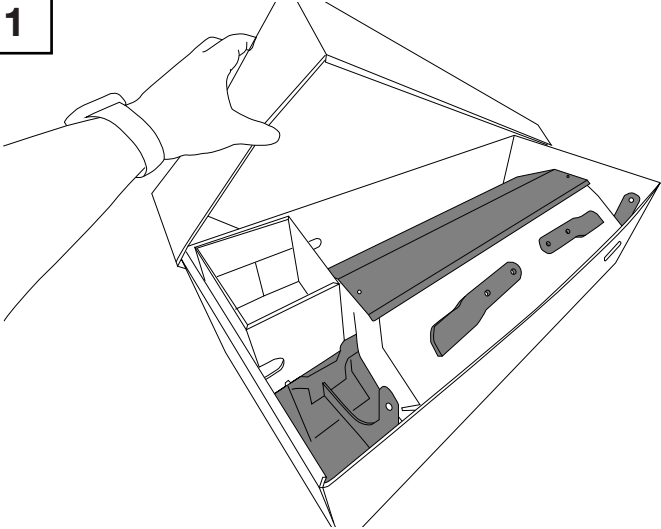

**Remove the nudge bar from its packaging.**



NOTE: The nudge bar is wrapped in protective tape to prevent damage during transport. Carefully remove each component and the cardboard inserts. If using a knife to open packaging, take care as damage to the powder coated finish may result.

2

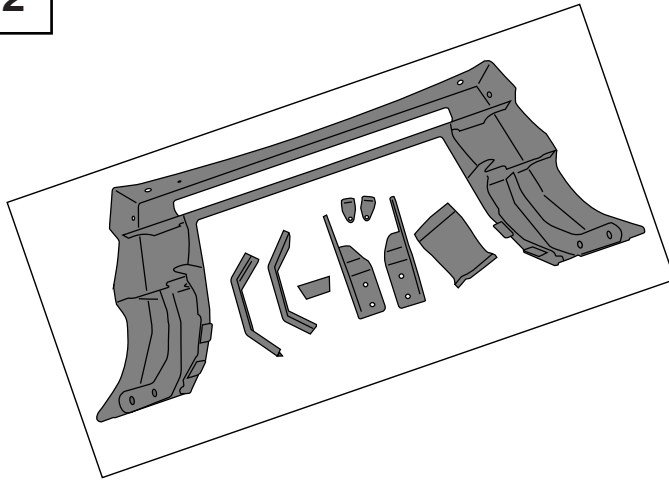

**Prepare the bar for fitting.**

Lay the bar face down on a protective surface such as cardboard or a blanket, preferably at bench height.

Unpack the fitting kit and check that all the components are complete as per the parts list.

3

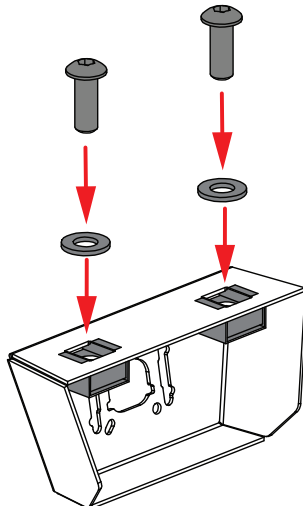

**For vehicles fitted with forward facing camera.**

Assemble the cage nuts (P/No. 602-0004) to the camera bracket P/No.300-0007) and fit to the nudge bar as shown using 2 x M6 x 16 hex head bolts (P/No. 601-0002) and 2 x flat washers (P/No. 603-0001)



Torque bolts to 9 Nm (7 lb-ft)

QUICK TIP!

Note there are 6 x cage nuts supplied in the kit. 2 have shorter tangs designed to suit the thinner material of the camera bracket

**4**

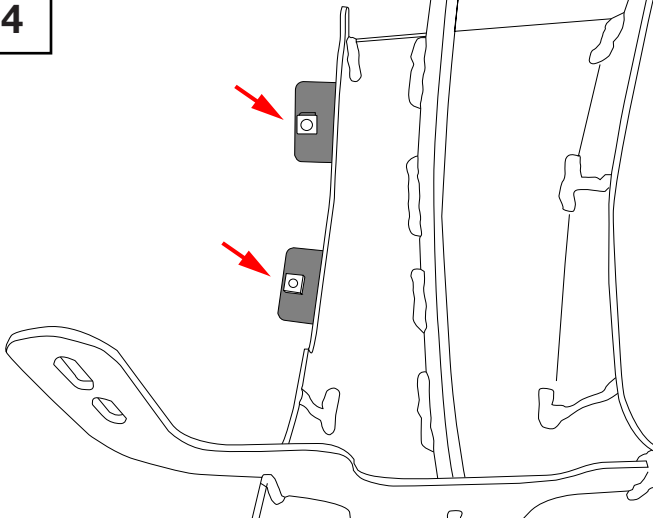

**Prepare the fasteners for attaching the centre pan.**

With the nudge bar facing down, place cage nuts (P/No. 602-0003) x 4, into the square holes on the 4 flanges as shown

Note: LHS shown, RHS same.

Ensure the nuts are fitted to the back of the flange.

**5**

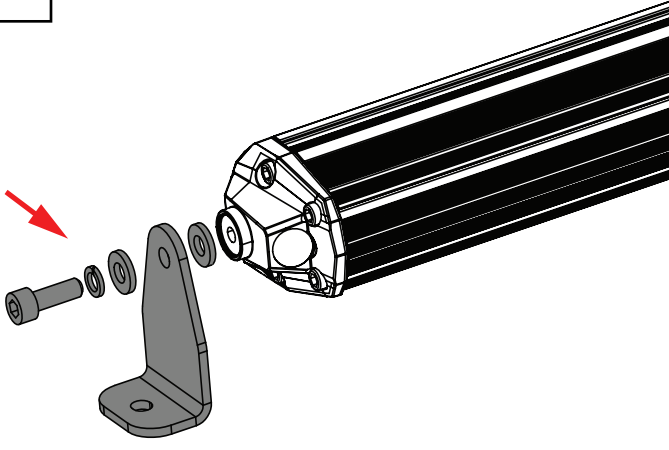

**Assemble the light bar brackets.**

Unpack the light bar from its packaging and locate the fitting kit.

Discard the mounting brackets (item 4) from the fitting kit.

Replace with the mounting brackets supplied in the nudge bar fitting kit (Part No. 300-0009) and assemble as shown.

Note: LHS shown, RHS same

**6**

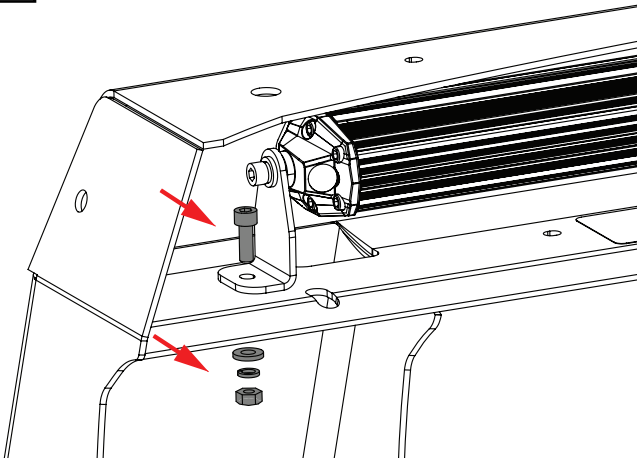

**Assemble light bar to nudge bar.**

Fit the light bar to the nudge bar using 2 x M6 x 20mm stainless cap screws, flat washers, spring washers and M6 stainless nuts (supplied in light bar fitting kit) as shown.

Note: LHS shown, RHS same

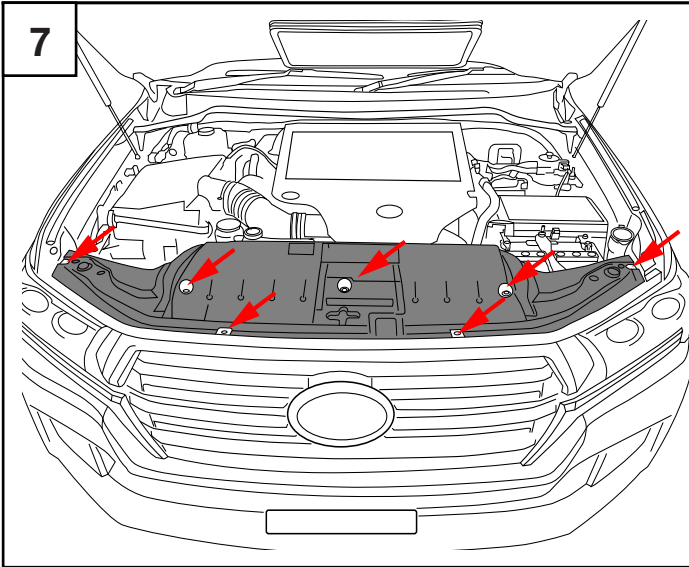

### Remove the radiator support cover panel.

Prior to raising the vehicle, remove the radiator support cover panel from the vehicle to access behind the grille.

Locate the 7 x push button clips as shown and depress the centre pins to disengage.

Lift the panel to remove and expose the rear of the grille and radiator support.

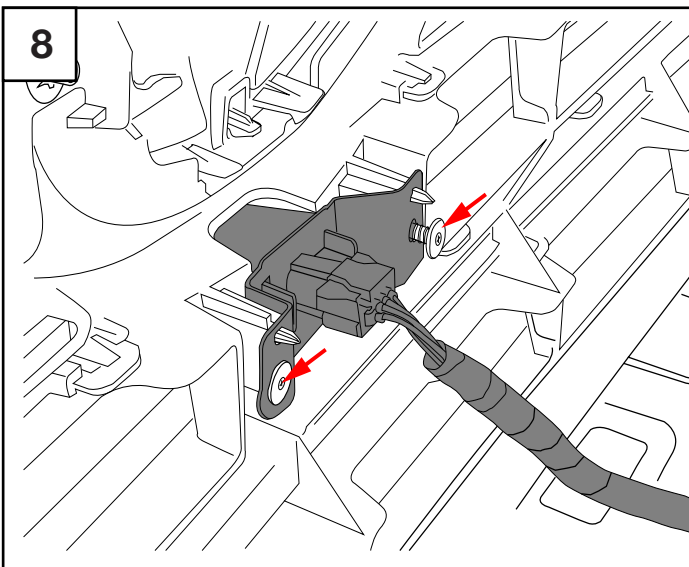

### For models fitted with forward facing camera.

Disconnect the wiring harness plug on the back of the camera.



Take care when removing the plug so as not to cause any damage.

The camera and bracket is retained in the grille by 2 x Phillips head screws. Using a # 2 Phillips head screw driver, remove the screws and the camera from the grille.

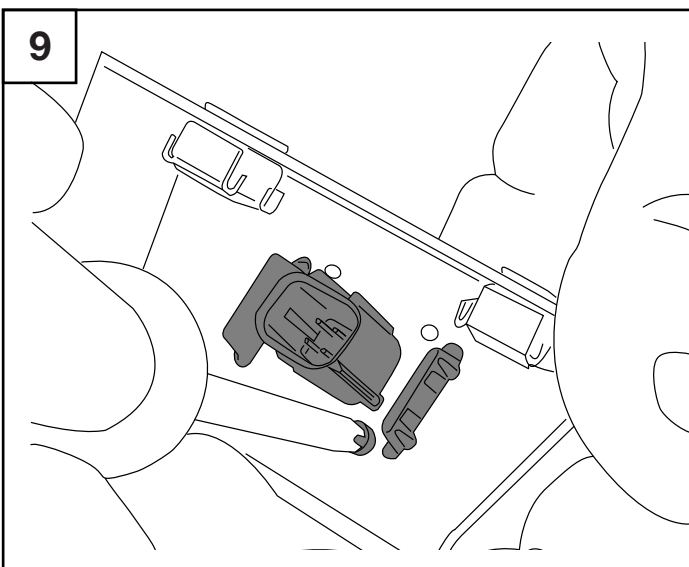

Remove the 2 x Phillips head screws that hold the camera to the original bracket using a #1 Phillips head screw driver. Depress the tangs that hold the camera into the bracket and remove.

Fit the camera to the new bracket as shown, ensuring the plastic tangs engage. Secure by reusing the two Phillips head screws.

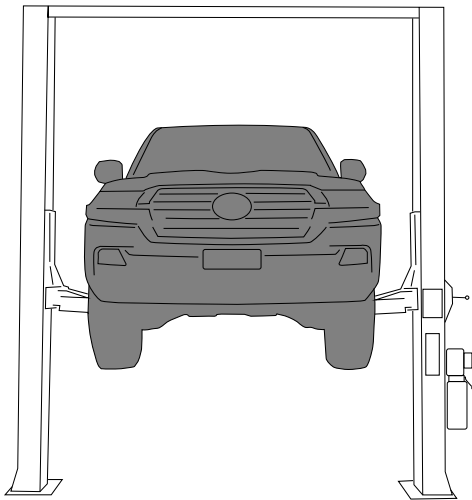
**10**

**Prepare the vehicle for fitment of the nudge bar.**

Note: Raising the vehicle - Always ensure the vehicle is supported by either vehicle stands or on a hoist. Consult the vehicle handbook for correct jacking locations. Never work beneath a vehicle on a jack or that is unsupported.

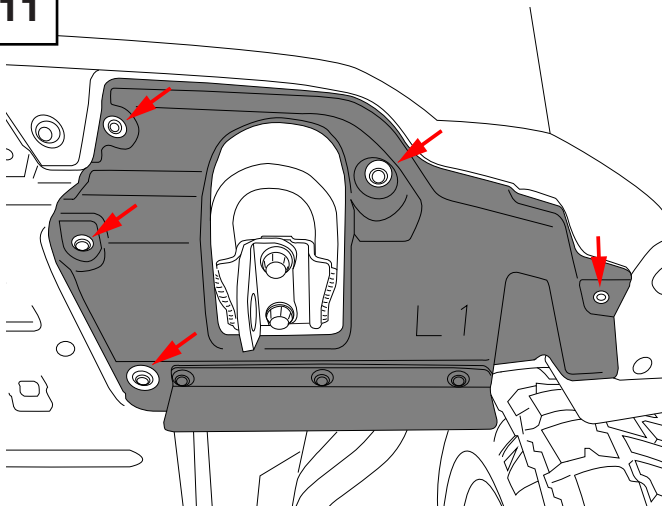

Wear eye protection when working beneath the vehicle as dirt and debris may be dislodged when removing bolts and under body panels.

**11**

**Remove the LHS & RHS wind deflector panels.**

Surrounding the vehicle tow points are wind deflector panels. Remove the fasteners as shown (3 x 10mm head bolts, 1 x 12mm head plastic nut & 1 x 10mm head screw).

Note: LHS shown. RHS same

Put aside to prepare for modification.

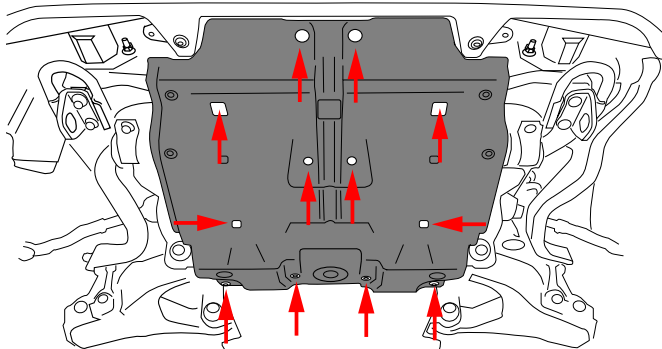
**12**

**Remove the engine splash guard.**

Remove 12 x M8mm bolts taking note of their positions as there are two different types used (one type has larger washers)

Note: The splash guard can be removed as one assembly, or in sections.

**13**

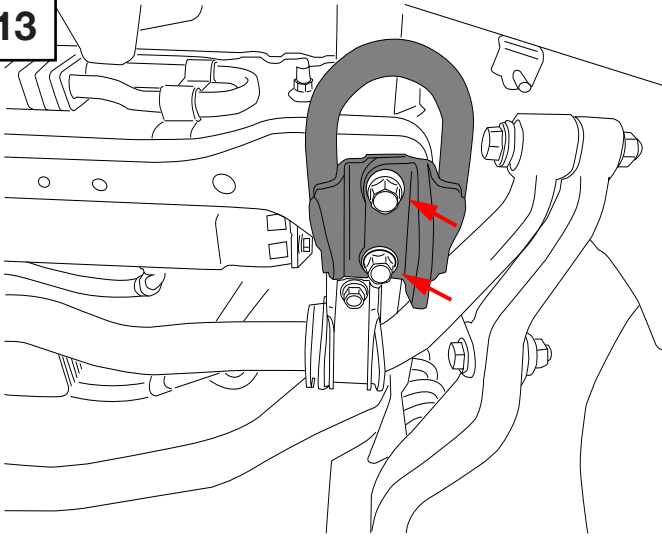

**Remove the LHS & RHS vehicle tow points.**

Remove the 4 x M12 bolts securing the left and right vehicle tow points. Mark each tow point so it can be refitted in the correct position.

Note: LHS shown, RHS same

**14**

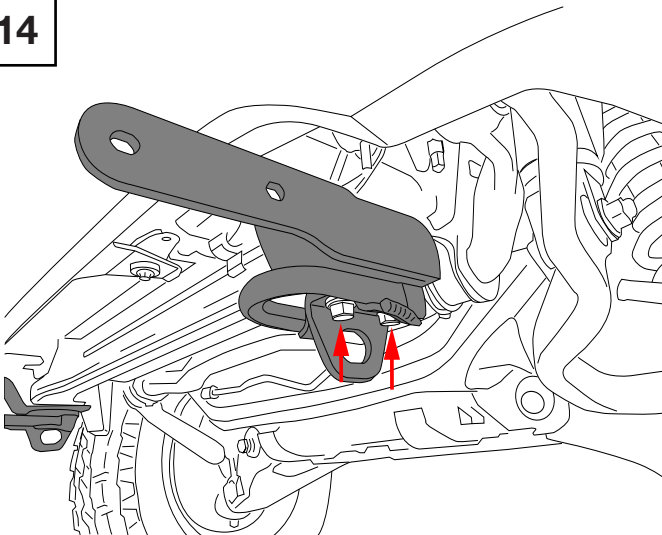

**Fit the left and right hand chassis mount assemblies.**

The chassis mount assemblies are sandwiched between the vehicle tow point and chassis and reuse the original tow point bolts.

Fit the chassis mount assemblies as shown. Refer to parts drawing for further detail.

Note: LHS shown, RHS same

**15**

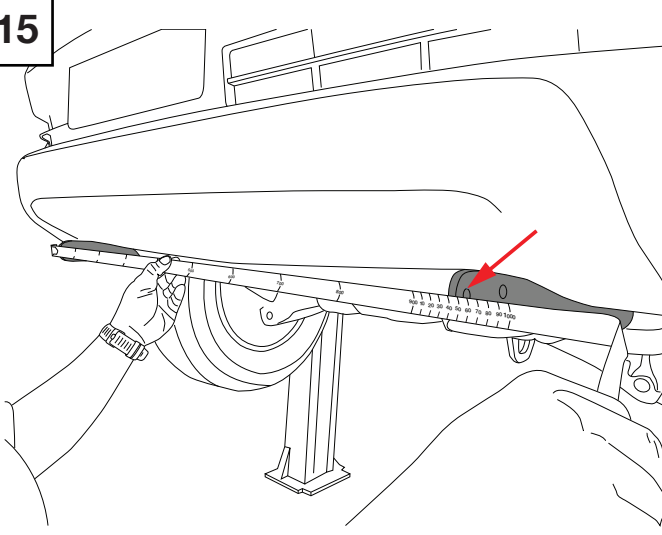

**Measure the chassis mount spacing.**

Using a tape measure check the width between the mounts (outside edges) as shown. Nominal 946mm +/-1mm

If the distance is too small or large, loosen the M12 bolts and adjust.

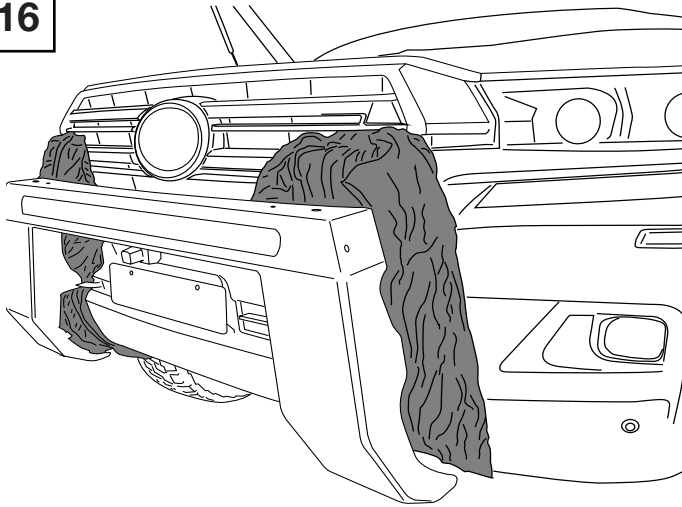

Torque the M12 bolts to 85 Nm (64 ft-lb)

**16**

**Mounting the nudge bar**

Note: This stage requires 2 or more people or a lifting device to lift & hold the nudge bar whilst it is bolted in place

Warning: Due to close proximity of bar fitment to the vehicle, care should be taken not to scratch or dent the body. Use protective tape or rags to protect areas of possible contact shown.

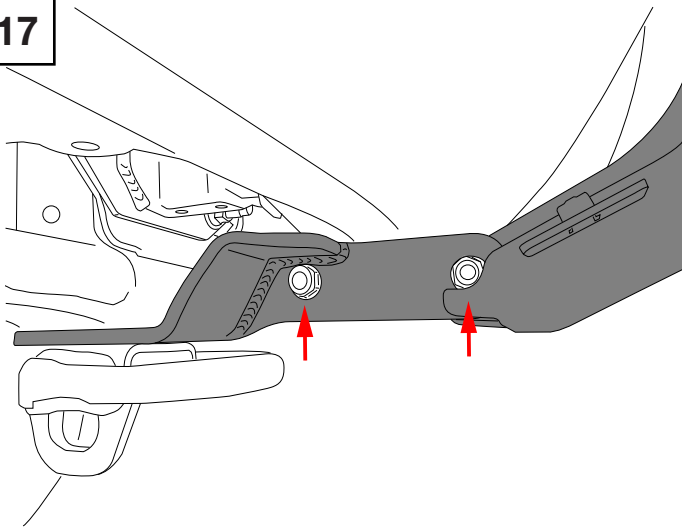
Note: Fitting antennas is best performed before fitting the nudge bar to the vehicle as access will be limited.

**17**

Lift the nudge bar into place. Install 4 x M12 bolts, flat washers and Nyloc nuts to hold the nudge bar to the mounts as shown (2 x per mount). Do not tighten at this stage.

Note: LHS shown, RHS same.

Note: Bolt threads should be facing inward as shown in the diagram.

Once in place, the nudge bar can be allowed to rest loosely on the mounts and protective tape/rags used in previous step can be removed..

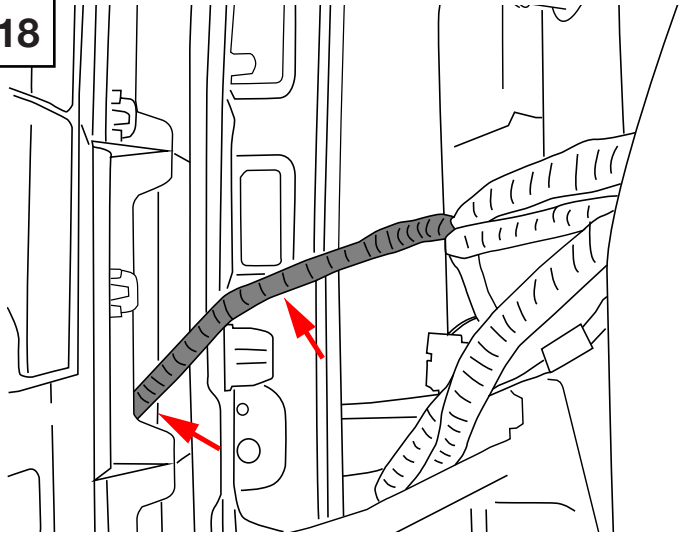
**18**

**For vehicles fitted with forward facing camera**

For ease of fitment, whilst the nudge bar is loosely mounted, route the camera wiring loom through the vehicle grille and connect it to the back of the camera.

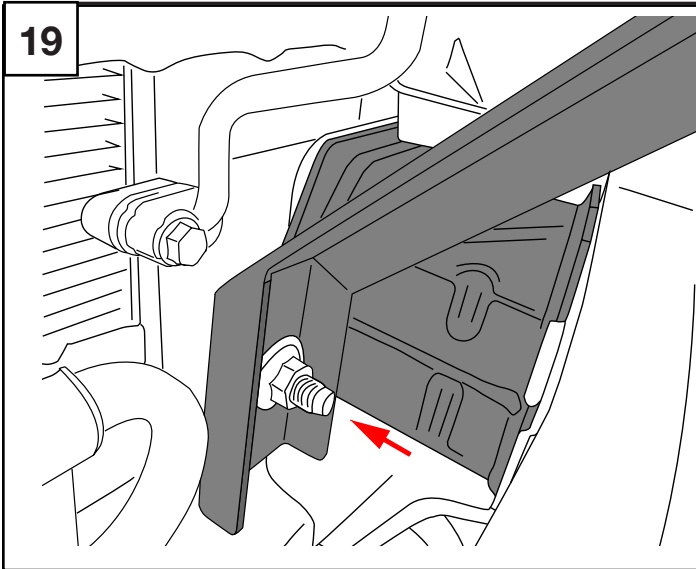
Use cable ties to secure to the grille lower support panel as shown to prevent movement and wear.



**19**

**Fit the support brackets**

Working from beneath the vehicle bumper, remove the inboard M10 flange nuts from the two crash beam mounts.

Fit the support brackets in place with the lower hole over the stud in the crash beam mount as shown.

When in place, the support bracket will sit below the corresponding mount on the nudge bar.

Note: LHS shown, RHS same.

Leave nuts loose so as to allow the nudge bar to be adjusted.

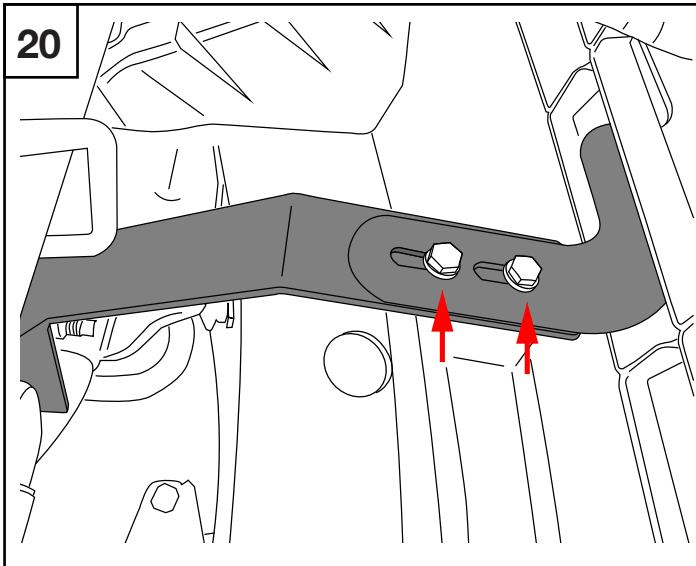

**20**

Reaching in between the top of the grille and support panel, attach the support bracket to the nudge bar using black M6 bolts and flat washers and M6 cage nuts.

Note: LHS shown, RHS same.

Leave bolts loose so as to allow the nudge bar to be adjusted.

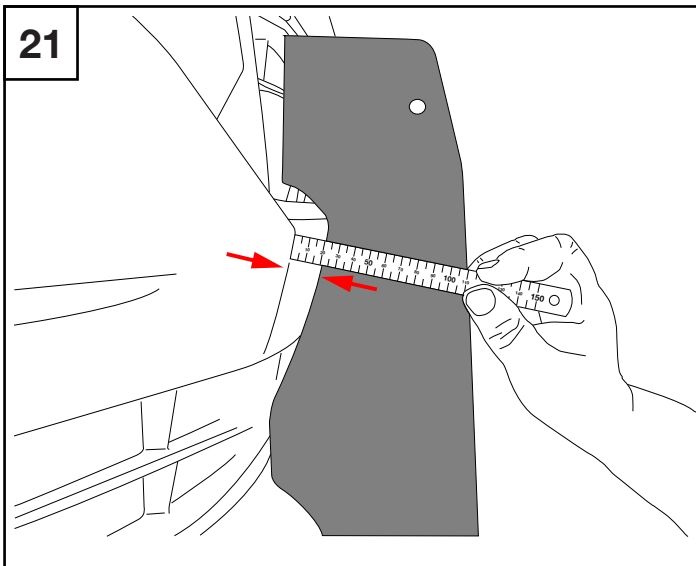

**21**

Adjust the nudge bar so that there is an even gap of approximately 20mm between the nudge bar and the vehicle bumper.



Note: tighten one of the chassis mount bolts first and adjust gap with support bracket adjustment



Tighten mounting bracket M12 bolts to 77 Nm (57 lb-ft)

Tighten the support bracket M6 bolts to 17Nm (13 lb-ft)

Tighten crash beam mount M10 flange nuts to 56 Nm (41 ft-lb)

**22**

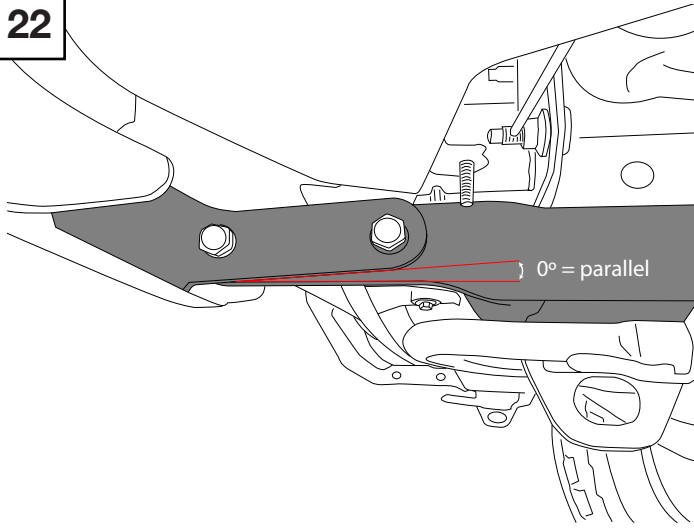

Note: Once fitted, the lower edge of the chassis mount on the vehicle and the nudge bar should be aligned parallel.

The image shown shows the brackets not aligned.

The lower edge of both brackets should be aligned.

**23**

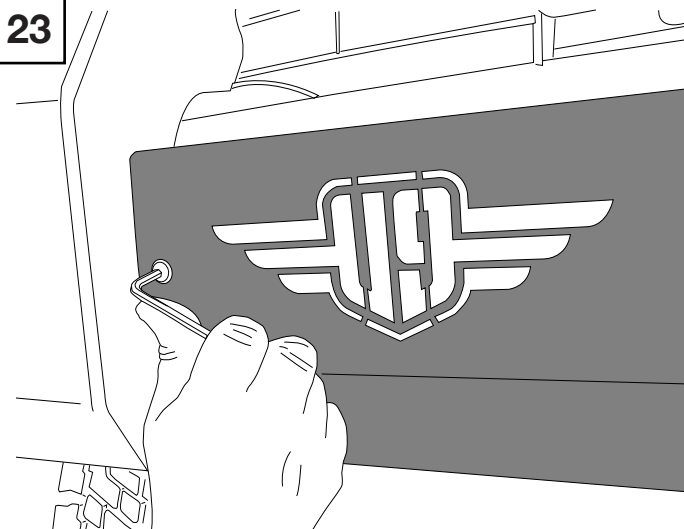

**Install the centre pan.**

Using 4 x M6 stainless steel cap screws and flat washers, install the centre pan as shown

**24**

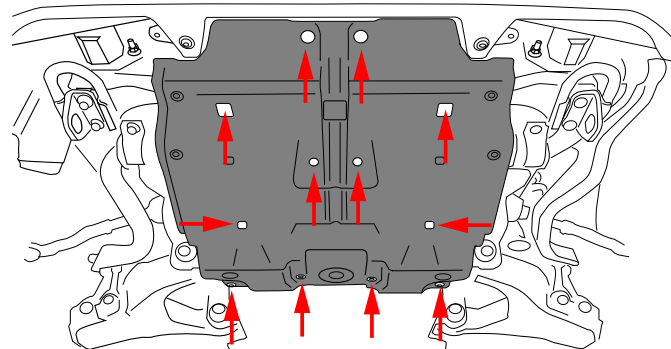

**Refit the engine splash guard**

Refit 12 x M8mm bolts taking note of their positions as there are two different types used (one type has larger washers)

Torque bolts to 15-22Nm (11-16 lb-ft)

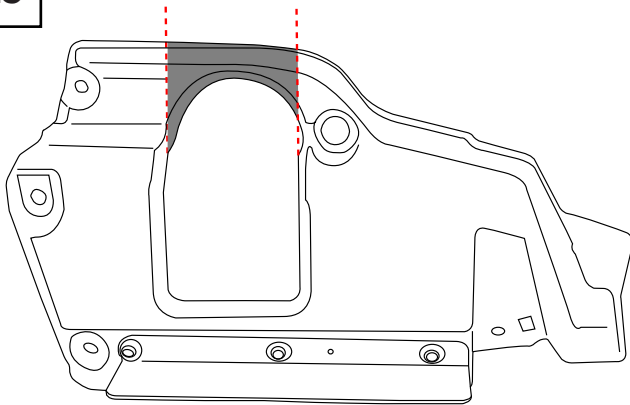
**25**

**Modify the wind deflector panels.**

The wind deflector panels require modification to allow refitting after fitment of the nudge bar. Mark the deflector panels as shown by the dotted line.

Note: LHS shown. RHS same

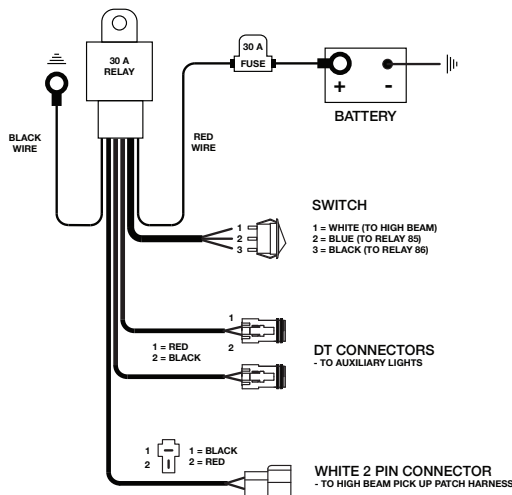

Trim the plastic as marked using tin snips, hacksaw or knife. Discard the excess material (shown in gray). Using a file or sand paper, remove any sharp edges to prevent injury.

**26**

**Install the wiring harness for the light bar**

Remove the wiring harness from the packaging and lay it out as shown.

Components to the harness are:

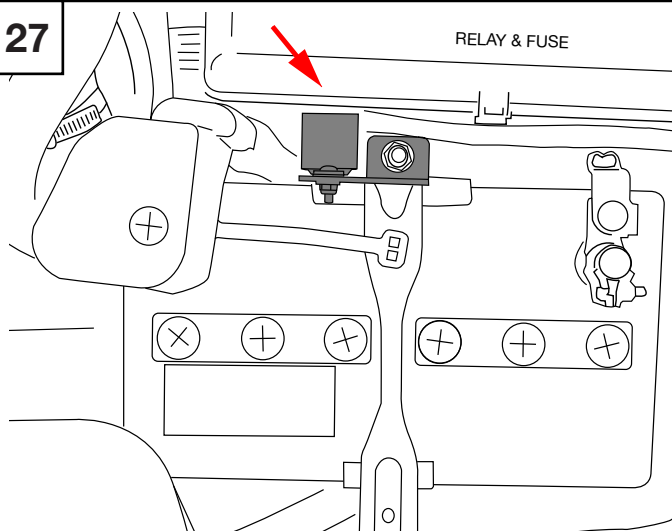
- Relay and mount
- Fuse and +/- wires
- Switch and cable
- DT connectors and cables
- Headlamp high beam pick up connector and cable
- High beam pick up patch harness (not shown)

**27**

**Mount the relay near the battery.**

Using relay mounting bracket, mount the relay to the relay bracket P/No. 300-0029 using M5 hardware, then attach the bracket to the battery hold down clamp as shown.

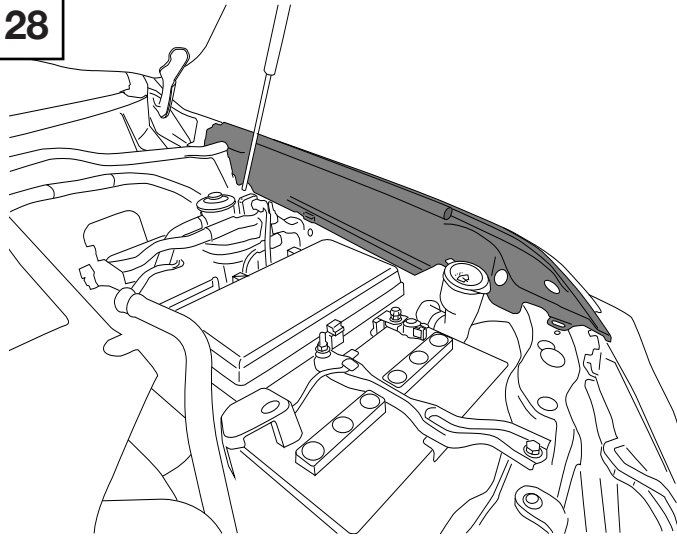
Note: do not connect positive and negative wires to the battery until step 39.

**28****Route the switch cable**

Using a trim removal tool, carefully remove the left hand guard inner trim panel as shown.

Note: There are 3 x trim clips. Gently pry the top of the panel away from the guard to expose.

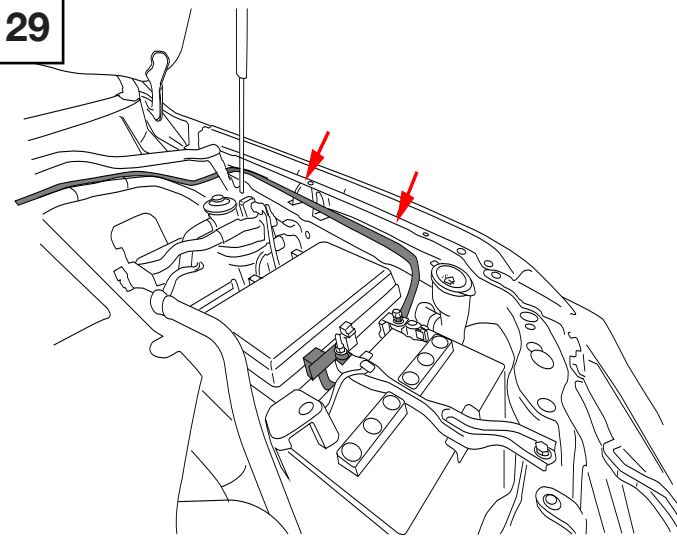
**29**

Route the switch cable carefully along the inside of the panel as shown and secure to the guard support brackets with cable ties.

Once the cable is secure, refit the trim panel removed in the previous step.

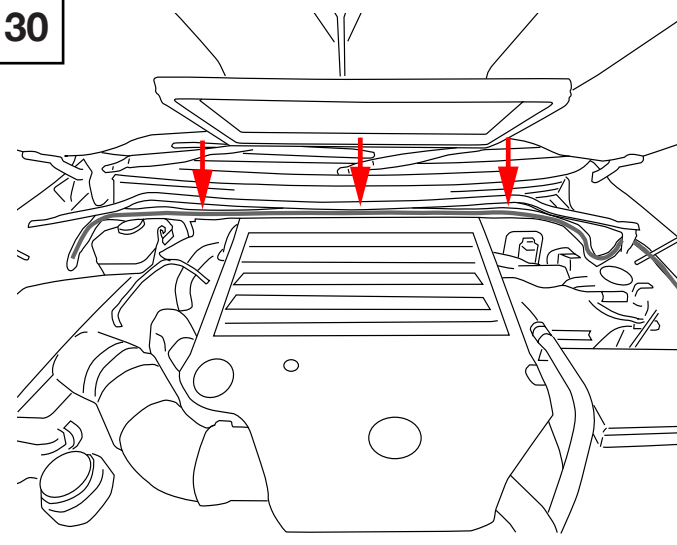
**30**

Route the switch cable along the factory loom at the rear of the engine bay, just below the bonnet seal as shown and secure with cable ties.

**31**

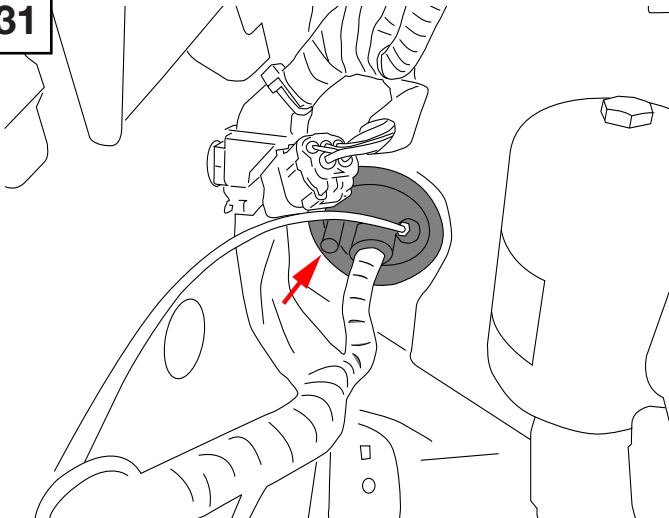

**Feed the switch cable into the cabin**

Remove the switch to enable the cable to be fed through the firewall and into the interior of the vehicle. Locate the firewall grommet in front of the drivers position and pierce the nipple as shown. Feed the cable through the grommet and into the cabin of the vehicle. Secure cable with ties.

**QUICK TIP!** Use plastic tubing as a pull through and lubricant such as silicon spray to help feed the cable through the grommet.

**!** Note: do not use solid wire such as a coat hanger as damage to other wiring may result.

**32**

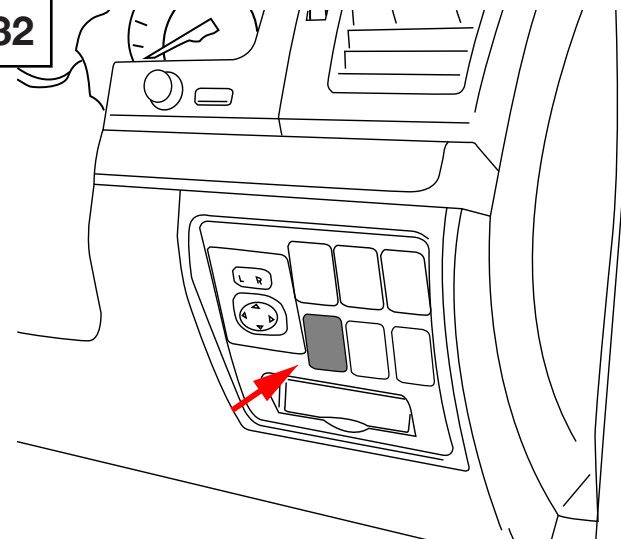

**Installing the switch**

Route the switch cable from the firewall to the switch panel on either the RHS or LHS of the steering column where there is a blank available for installing the switch. Secure the cable with cable ties to ensure it does not interfere with the operation of pedals/controls etc.

Note: RHS switch panel shown.

 Carefully remove the trim panels to gain access to the rear of the switch panel using plastic trim removal tools. Remove the chosen blank from the panel.

**33**

**SWITCH HOLE**

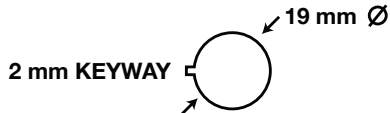

19 mm Ø

2 mm KEYWAY

Either the round switch supplied with the harness or the factory style switch may be used to power the harness/light bar.

 If the round switch is used, a 19mm hole needs to be drilled in a suitable location as shown.

**QUICK TIP!** A step drill is best used for this which will result in a 20mm hole however the switch will still fit snugly.

To prevent the switch from rotating, the small key way slot should be filed.

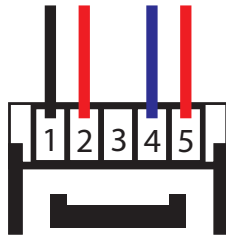
**34**

Switch plug as viewed from rear with clip at bottom

- 1 - to harness BLACK (Earth)
- 2 - to dash lighting illumination circuit
- 3 - not used
- 4 - to harness BLUE (Power out to relay)
- 5 - to harness WHITE (Power in from high beam)

Note: The illumination circuit on Toyota vehicles is typically the green wire on the back of dash switches.

If using the factory style switch supplied:

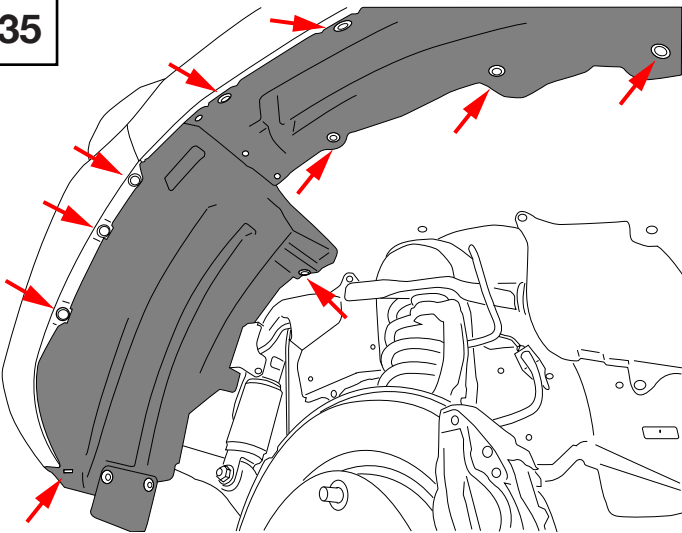

1. Using wire strippers, strip back each wire on the factory style switch plug and using Ultilux #124 Crimping tool or similar, attach the supplied connectors to wires # 1,4 & 5.
2. Connect the factory style switch plug wires, No. 1,4 & 5 to the switch cable as described in the diagram. NOTE: Colours of the wires on the switch will not match the harness switch cable so take note of the position of the wires viewed from the back of the plug in the switch.
3. Connect wire No. 2 to the illumination circuit of the vehicle by splicing into an existing switch/loom using the Scotchlok type connector supplied.
4. Push the switch into the panel until it locks in place.

**35**

**Connecting the headlamp pickup cable to the high beam pick up patch harness.**

Remove the LH front wheel and the inner wheel arch panel to gain access to the headlamp harness connector for the LH headlamp.

Note: there are 3 x T30 torx screws, 1 x 10mm screw and up to 12 plastic clips that require removal.

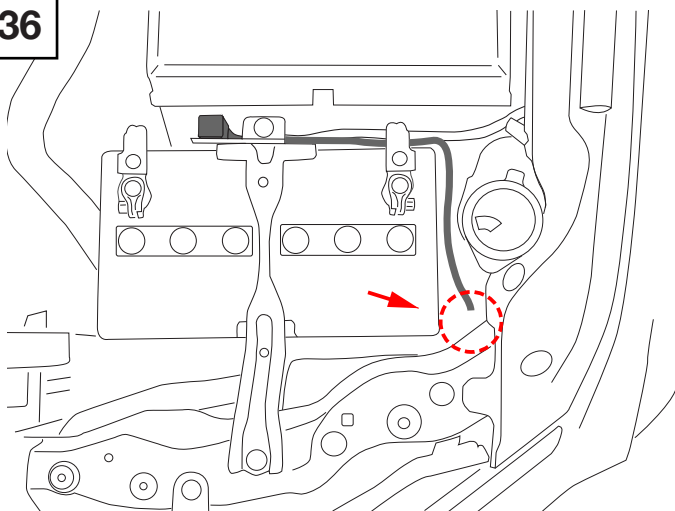

The inner guard panel can be maneuvered out of the way without complete removal by removing fasteners from the front half only

**36**

The headlamp harness connector is located behind the bumper near the fog light assembly.

Route the headlamp high beam pick up cable from the relay down to between the back of the headlamp and the battery, through the opening in the support panel and down to where the fog light is mounted in the front bumper.

Use cable ties to secure to other wiring to ensure it can't rub on panel edges.

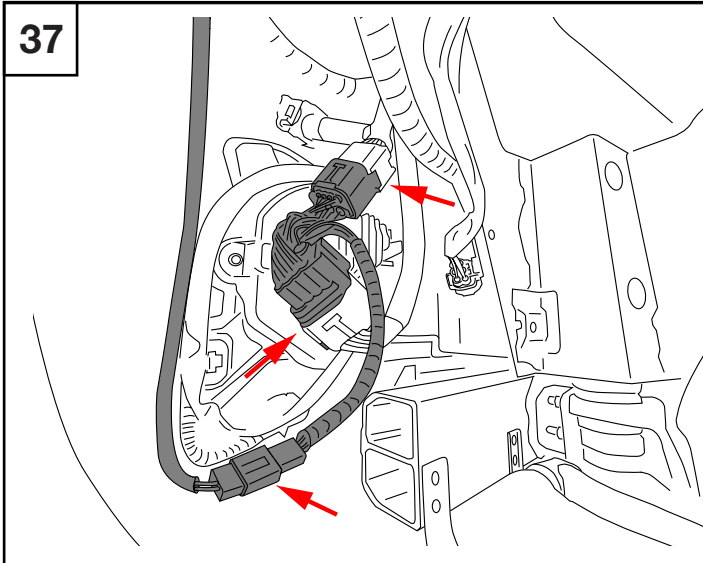

Locate the headlamp harness connector positioned near the back of the fog light and carefully disconnect.

Install the high beam pick up patch harness and connect the high beam pick up cable as shown.

Secure with ties to existing cables to prevent movement and rubbing.



Familiarise yourself with the connector to make it easier to disconnect by checking the connectors on the piggyback harness first.

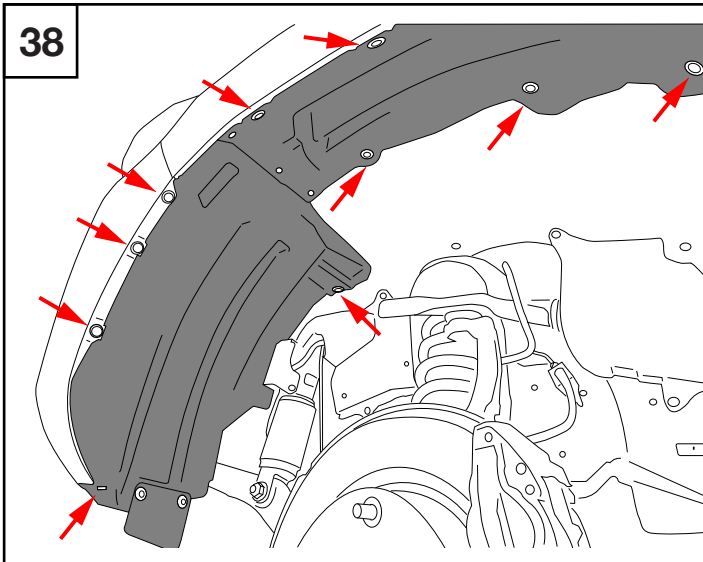

Replace the plastic inner guard removed in step 35 and tighten all fasteners.



Replace the wheel and torque wheel nuts as per manufacturers specifications.

Alloy wheels 131 Nm/97 lb-ft  
 Steel wheels 209 Nm/154 lb-ft

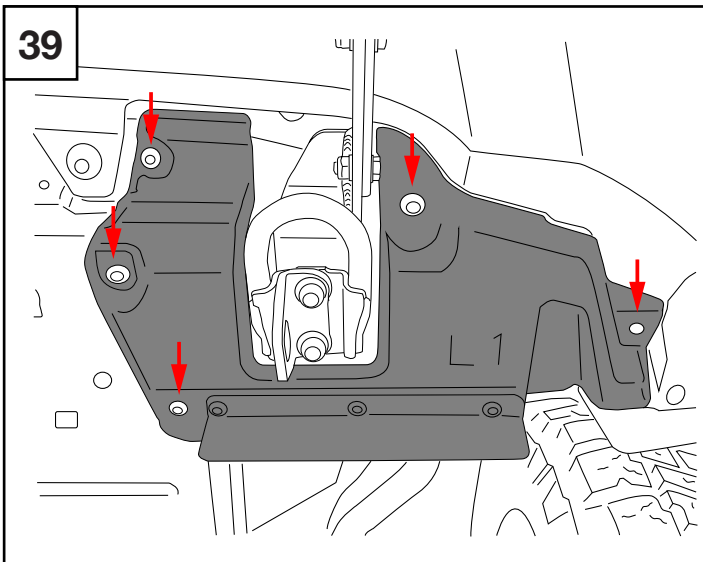

Replace the modified LH & RH wind deflector panels around the vehicle tow points as shown.

Torque bolts to manufacturers specification.

The vehicle can now be lowered back to ground.

**40**

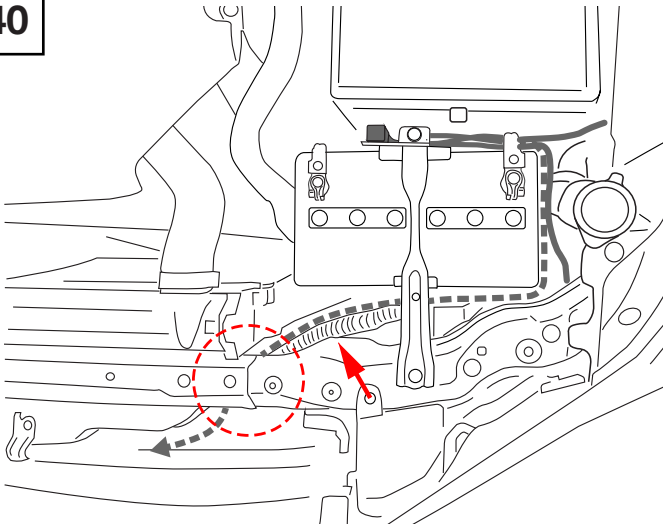

Route the two cables with DT connectors from the relay, around the battery through the radiator support panel near the radiator, following the existing cables as shown.

Connect one DT connector to the light bar by passing the light bar fly lead through the lower part of the grille.

Note: the second connector is for the addition of a second light bar to the nudge bar if required.

Secure all cables neatly with cable ties so as not to move or rub on other components.

**42**

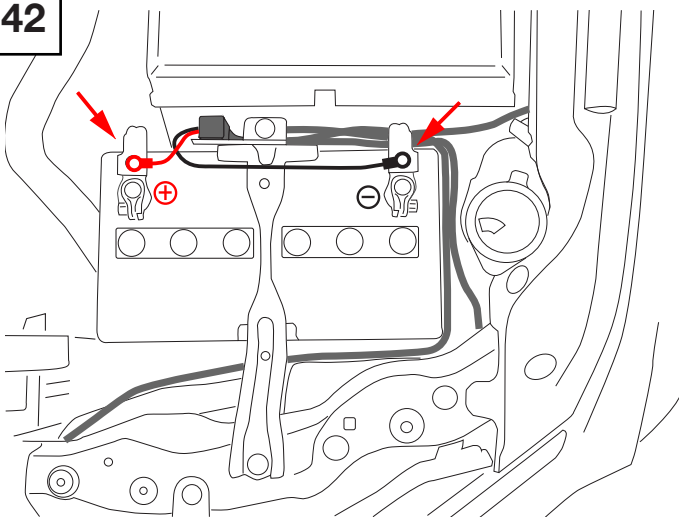

Connect the positive (red) and negative (black) wires to the battery. Ensure cables are secured with cable ties to prevent wear.

**Test the operation of the light bar**

Turn the vehicle ignition on and switch on the headlights. Check headlights for correct operation of high and low beam.

With the headlamps on high beam, depress the driving light switch. Check that the switch illuminates and that the light bar turns on. toggle the headlamps between high and low beam to check driving light switches on and off with high beam.

**43**

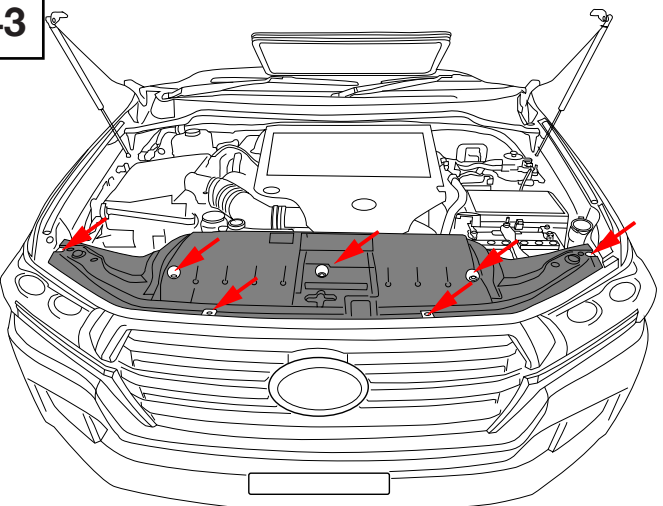

Replace the radiator support cover panel and refit 7 x push button clips.

Hint: if any clips are damaged or missing, they can be ordered from Toyota with genuine part number 90467-07217 Clip, Radiator support to frame seal.

**44**

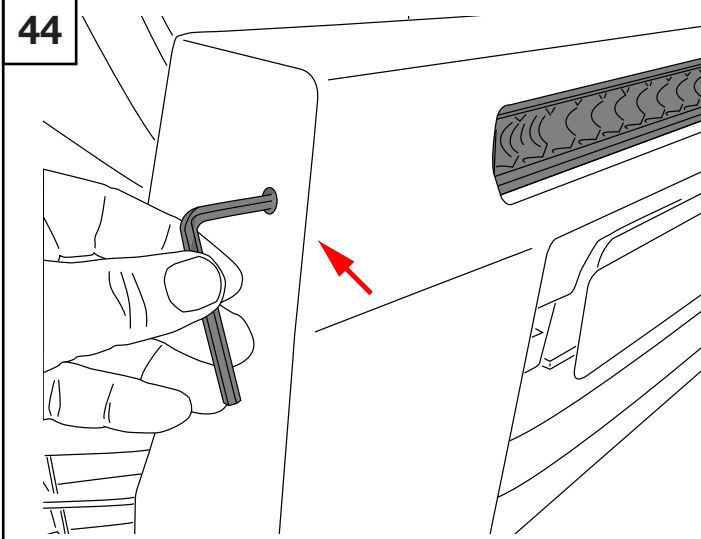

**Adjusting the light bar**

The light bar can be adjusted initially against a wall. Park the vehicle approximately 7.5 meters from the wall and switch the high beam lights on. If the light bar is not already on, switch on by depressing the switch.

Included in the light bar fitting kit is a long 5mm Allen key, Insert the Allen key through the hole in either side of the light bar as shown to loosen/tighten the cap screws in the light bar mount.

Adjust the beam of the light bar so that it sits at a similar height to the high beam pattern. Re-tighten the light bar mount cap screws.

Fine tuning of the light bar can be performed at night on a quiet road.

## WARRANTY

Ultimate9 provides to the original purchaser, a 12 month warranty against manufacturing faults or defects. Conditions resulting from normal wear & tear, modification, misuse, abuse or incorrect fitment are not covered and will void the warranty.

In order to make a claim under this warranty, the purchaser must:

- Return the product to the place of purchase with a valid receipt/invoice or proof of purchase or contact Ultimate9 customer service on 03 9729 8515.
- Provide Ultimate9 with any additional information as requested.

The purchaser is responsible for any return freight or fitting/removal costs incurred when making a claim under this warranty unless communicated otherwise by Ultimate9.

This warranty is limited to the original purchaser and is not transferable.

*Our goods come with guarantees that cannot be excluded under the Australian Consumer Law. You are entitled to a replacement or refund for a major failure and compensation for any other reasonably foreseeable loss or damage. You are also entitled to have the goods repaired or replaced if the goods fail to be of acceptable quality and the failure does not amount to a major failure.*

HEAD OFFICE	POSTAL ADDRESS	DELIVERY ADDRESS	CONTACT
Ultimate9	Factory A/28a Kalman Drive, Boronia VIC, 3155	Factory A/28a Kalman Drive, Boronia VIC, 3155	T +61 3 9729 8515 E sales@ultimate9.co W www.ultimate9.co